

Galvanic corrosion behavior of titanium implants coupled to dental alloys

M. CORTADA, LL. GINER, S. COSTA

Facultad de Ciencias de la Salud, Universidad Internacional de Cataluña, Campus de San Cugat del Vallès, Barcelona, Spain

F. J. GIL, D. RODRÍGUEZ, J. A. PLANELL

Dept. Ciencia de los Materiales e Ingeniería Metalúrgica, E.T.S. Ingeniería Industrial de Barcelona, Universitat Politècnica de Catalunya, Spain

E-mail:gil@cmem.upc.es

The corrosion of five materials for implant suprastructures (cast-titanium, machined-titanium, gold alloy, silver-palladium alloy and chromium-nickel alloy), was investigated *in vitro*, the materials being galvanically coupled to a titanium implant. Various electrochemical parameters (E_{CORR} , i_{CORR} Evans diagrams, polarization resistance and Tafel slopes) were analyzed. The microstructure of the different dental materials was observed before and after corrosion processes by optical and electron microscopy. Besides, the metallic ions released in the saliva environment were quantified during the corrosion process by means of inductively coupled plasma-mass spectrometry technique (ICP-MS). The cast and machined titanium had the most passive current density at a given potential and chromium-nickel alloy had the most active critical current density values. The high gold content alloys have excellent resistance corrosion, although this decreases when the gold content is lower in the alloy. The palladium alloy had a low critical current density due to the presence of gallium in this composition but a selective dissolution of copper-rich phases was observed through energy dispersive X-ray analysis.

© 2000 Kluwer Academic Publishers

Introduction

Corrosion manifestations on dental alloys may exhibit biological, functional and aesthetic effects, of which the biological effects are of greatest significance. In corrosion processes metal ions are released and may come into contact with cells and tissues in the close environment, or be distributed throughout the entire body. If these ions are not biocompatible, the organism may be injured (toxicity and risk of sensitization). Therefore, the ultimate goal must be to only use those alloys with minimal metal ion release [1].

Titanium was chosen as an implant material primarily on account of its inert behavior towards hard tissues, with the formation on its surface of a direct bony accretion, which was described as an osseointegration phenomenon [2–5]. While it is unanimously agreed that titanium has proved its qualities as a material for endo-osseous implantation, the choice of a suitable alloy for the suprastructure remains an open subject of study. Thus this choice has to be made by taking into account the corrosion resistance when the alloy is coupled with titanium, the biocompatibility, and the clinical studies of the relationship between the metal and the epithelium or the subepithelial connective tissue or bone tissues [6].

In vitro electrochemical techniques have been proven to be sufficiently sensitive to measure even a low

corrosion rate, moreover they are quick and convenient and are now used by many researchers [7–11].

The aim of this article is to compare the corrosion behavior in artificial saliva solution of five suprastructures materials at 37 °C and to investigate the effects of chemical composition on their corrosion behavior. By means of inductively coupled plasma-mass spectrometry to determine the types and amounts of metal ions released from these couples and based on these data, recommendations can be made for connecting titanium implants to different alloy suprastructures for the health and comfort of patients.

Material and methods

The chemical composition of the titanium and the dental alloys studied is given in Table I.

Five samples were tested in the form of small cylinders (2 mm diameter and 3 mm height) connected to a stem in order to establish the electrical contact for each dental material studied. They were polished metallographically with diamond paste from 5 µm to 0.1 µm. Titanium implant and dental alloy couples were kept immersed in the electrolyte for all the measurements taken. The electrolyte is an artificial saliva at a temperature of 37 °C and pH 6.7 with the composition given in the Table II.

TABLE I Chemical composition of the dental materials studied in weight percentage

Materials	Chemical composition
Implant	Titanium commercially pure grade 1 (>99.9% Ti)
Machined titanium	Titanium commercially pure grade 2 (>99.5% Ti)
Casting titanium	Titanium commercially pure grade 2 (>99.5% Ti)
Palladium alloy	73.7% Pd, 14.9% Cu, 11.4% Ga
Chromium-nickel alloy	76.5% Ni, 14.3% Cr, 5.6% Al, 2.3% Mo, 0.8% Si y 0.5% Fe
Gold alloy	50.0% Au, 31.5% Cu, 13.0% Ag, 5.4% Zn.

TABLE II Chemical composition of the artificial saliva

Compound	Composition (g/dm ³)
K ₂ HPO ₄	0.20
KCl	1.20
KSCN	0.33
Na ₂ HPO ₄	0.26
NaCl	0.70
NaHCO ₃	1.50
Urea	1.50
Lactic acid	up to pH = 6.7

The schematic electrical set-up used to measure the electrochemical parameters is shown in Fig. 1. The corrosion cell used is a glass cell with the working electrodes and a saturated Ag/AgCl electrode used as a reference. The distance from the reference electrode to samples was 25 mm. The ratio of anode surface to the cathode surface was equal to one.

The current versus time in the galvanic coupling studied was controlled by an Hewlett Packard potentiostat. The variation of the potentials in an open a short circuit was controlled by a digital multimeter & scanner. Using this type of assembly it is possible to measure at the same time the current and the common potential (short potential) versus time of the galvanic coupling studied. Similar assemblies were used by other authors in measurements of Evans diagrams of galvanic couplings [6, 12–15]. The overall system was controlled using PC-compatible computer. The preparations of the samples and the corrosion test carried out followed the ASTM standards G8 and G15.

The couplings were subjected to the following measuring cycle:

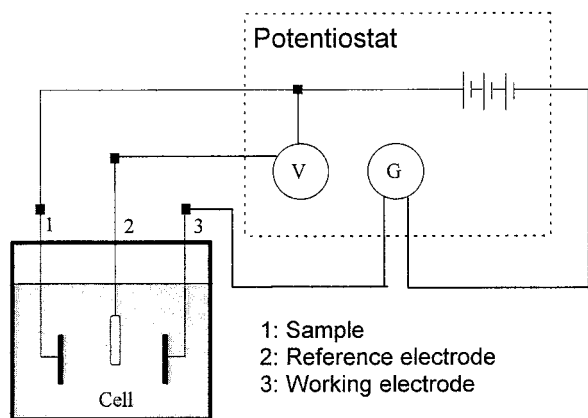

Figure 1 Schematic electrical set-up used to measure the electrochemical parameters.

- Immersion in the de-aerated electrolyte for 250 min with recording of the open potential of each electrode.

- By means of a potentiostat, the potential was increased at intervals of 50 mV up to 1.6 V. Recordings of the variation of the galvanic current density, potential, etc. were obtained and the Tafel slopes were determined from the Evans diagrams. In order to determine these diagrams, it is very important to record the polarization curves in a pseudostationary manner. In our case, the 250 min of immersion of specimens was sufficient.

The microstructure of the different dental materials were observed before corrosion processes by optical microscopy. The corroded surfaces were observed by scanning electron microscopy in order to observe the pitting zones and by means of X-ray dispersive energy microanalysis can determine the chemical composition of the places more prone to corrode.

Five specimens of each galvanic coupled system were placed in a container with artificial saliva. The surface of the samples was of 770 mm² and the volume of the fluid was 250 ml. Ten millilitres of solution was extracted at different times in order to analyse the metallic ions released. The container was perfectly protected in order that no impurity interfered with the results. The quantification of the ions released was carried out by ICP-MS measurement. This spectrometric technique facilitates the quantification of chemical elements in very diluted solutions, even as little as parts per billion (nanograms/millilitre). This considerable sensibility is due to the use of Argon plasma which works at temperatures between 8000 and 9000 °C at which almost all materials are ionized. These measurements were carried out with samples taken at 1, 3, 5, 10, 24, 120, 168, 360 and 560 h.

Results and discussion

The corrosion rates of alloys used for dental applications can be easily determined by electrochemical methods, because of their extremely low corrosion rates. This technique also permits repeated corrosion measurements on the same sample.

Figs 2 to 6 show the variation in the current generated by the couples versus the variation in potential of the couples. Table III shows the results of the different corrosion magnitudes adapted to internationally acknowledged definitions used in ISO/CD 10271 (“Dental Metallic Materials-Corrosion Test Methods”):

- *Open circuit potential* (E_{OCP}), Potential of an electrode measured with respect to a reference electrode

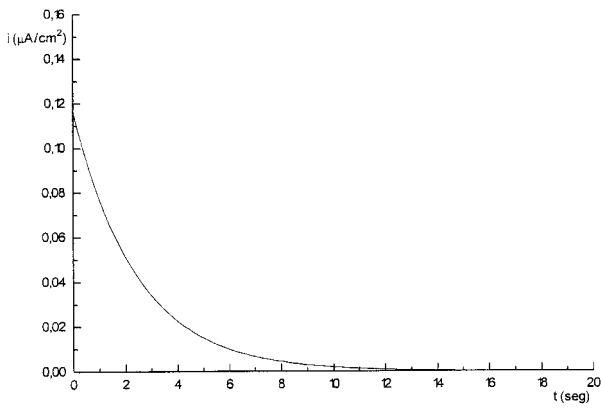

Figure 2 Current generated versus potential of the couple gold alloy—titanium.

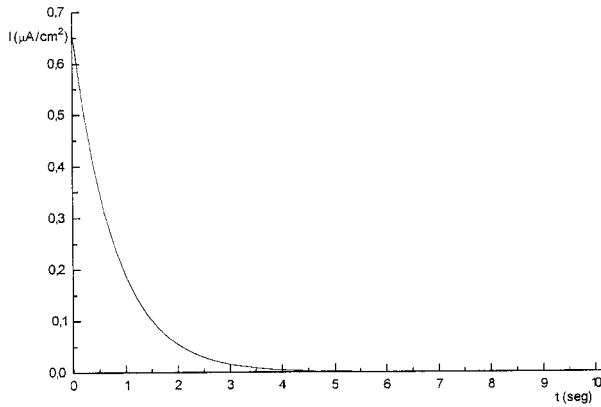

Figure 3 Current generated versus potential of the couple palladium alloy-titanium.

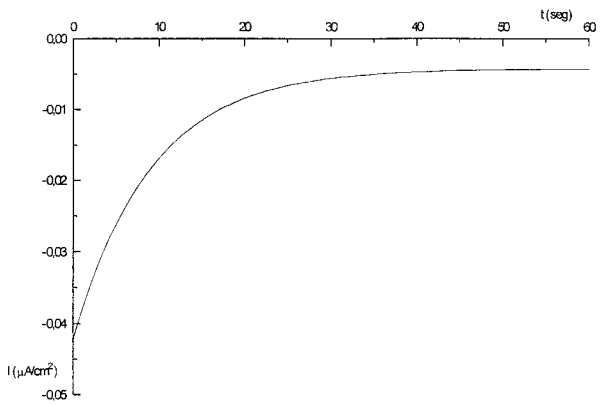

Figure 4 Current generated versus potential of the couple nickel-chromium alloy-titanium.

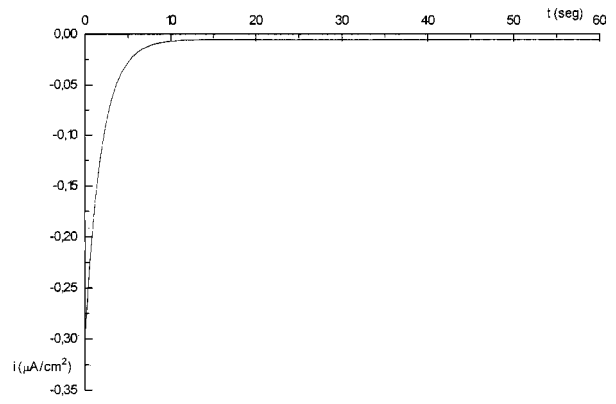

Figure 5 Current generated versus potential of the couple machined titanium-titanium.

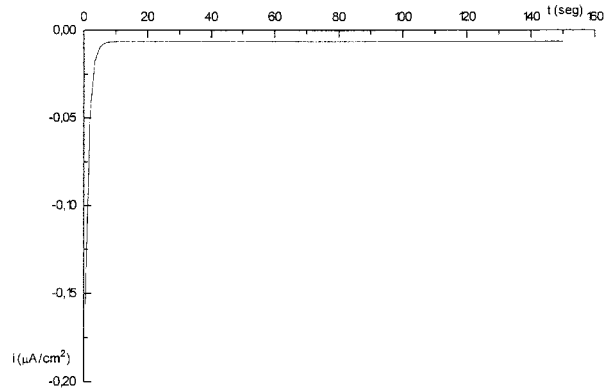

Figure 6 Current generated versus potential of the couple cast titanium-titanium.

or another electrode when no current flows to or from the material.

- *Zero current potential (E_Z)*, Potential where cathodic and anodic currents are equal in a polarization test of the couple Ti implant-alloy.

- *Corrosion Potential (E_{CORR})*, Potential calculated at the intersection where the total oxidation rate is equal to the total reduction rate.

- *Corrosion current density (i_{CORR})*, Current divided by the surface of the electrode. It is the size of the anodic component of the current which flows at the corrosion potential E_{CORR} . Since by definition the resulting current is equal to zero at that potential, the cathodic component is of equal size, but of opposite sign. The measured resulting current being zero at the corrosion potential, the corrosion current density i_{CORR} can only be obtained by

TABLE III Mean values obtained from potentiostatic polarization plot of dental materials studied in artificial saliva solution

Material	E_{OCP} (mV)	E_Z (mV)	E_{CORR} (mV)	i_{CORR} (mA/cm ²)	Anodic current (mV)	Cathodic current (mV)
Ti-cast	2 ± 2	-73 ± 12	-10 ± 3	$-8.0 \cdot 10^{-6}$ $\pm 2.0 \cdot 10^{-7}$	195 ± 12	55 ± 3
Ti-machined	-12 ± 4	-211 ± 15	-75 ± 9	$-7.1 \cdot 10^{-6}$ $\pm 3.0 \cdot 10^{-7}$	420 ± 5	180 ± 9
Gold alloy	-63 ± 6	86 ± 11	154 ± 12	$3.5 \cdot 10^{-5}$ $\pm 1.0 \cdot 10^{-6}$	373 ± 15	150 ± 17
Pd alloy	290 ± 12	155 ± 9	50 ± 12	$4.0 \cdot 10^{-6}$ $\pm 1.0 \cdot 10^{-6}$	283 ± 21	81 ± 9
Cr-Ni alloy	8 ± 3	-243 ± 20	285 ± 23	$1.1 \cdot 10^{-4}$ $\pm 8.0 \cdot 10^{-6}$	150 ± 8	145 ± 12

indirect methods, e.g. by the Tafel equation. Tafel constants a and b : a and b are the Tafel proportionality constants for anodic (oxidation) and cathodic (reduction) reactions of a metal.

The results of the zero current potential adopted by the couples are within the range of -243 mV for Ti implant/chromium nickel alloy couple and $+155$ mV for Ti implant/palladium alloy couple. It may be noted that the potentials in an open circuit and the zero current potential of the couples of the precious alloys adopt positive values. The precious alloys remain in their immunity range and will therefore act as cathode, while the titanium will be under anodic control. For the non-precious alloys, the open potential shows negative values.

The higher the current density at a given potential, the more prone is the material to corrode. Cast and machining titanium had the most passive ($-8.0 \cdot 10^{-6}$ and $7.1 \cdot 10^{-6}$ mA/cm²) and chromium-nickel alloy had the most active ($1.1 \cdot 10^{-4}$ mA/cm²) critical current density values.

The difference of the current density at a given potential between cast and machined titanium is due to the internal stresses produced in the surface of the titanium machined that favor the corrosion processes. All the cast samples presented the same grain size (20–25 μ m) because the grain boundaries affect at the corrosion behavior. When the samples have a small grain size show higher critical current density than the bigger grain size because the grain boundaries store internal energy which favors the corrosion.

From Table III can be seen the Tafel slopes, the non-corrodible alloys, which are either passive or in the process of passivation have slopes values of $a < b$. In contrast, alloys tending to corrode spontaneously have slope values $a > b$. The anodic slope for chromium-nickel alloy is 150 mV and cathodic slope 145 mV. These values are very similar and therefore the tendency to corrode is greater than for the other alloys studied.

Noble and semi-noble alloys

The high-gold alloys have all excellent resistant to corrosion. Pitting corrosion was not found. The corrosion resistance of these alloys is due to the high thermodynamic stability of the gold in the alloys [16–19]. Although the alloys are considered to have good corrosion resistance, metallic ions are released to the surrounding environment. This observation has been reported in both *in vitro* and *in vivo* studies [17, 19, 20]. In low-gold alloy, as the alloy of the present study, corrosion occurs primarily in silver-rich regions and secondarily in copper-rich regions, as was corroborated by other studies [16, 21]. Corrosion attacks occur primarily in the grain boundaries, where silver segregation were localized, as can be seen in Fig. 7.

The ion release in the gold alloy attached to the titanium oral implant increased more slowly than in the rest of the alloy studied and moreover the amount of ions released tended to become stabilized as time goes by, as can be observed from the results shown in Fig. 8. What is

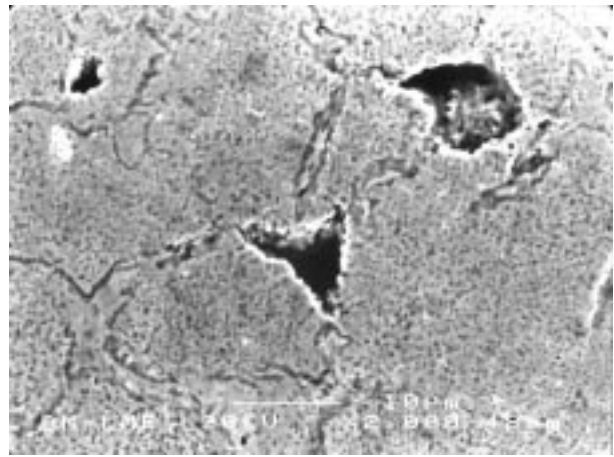

Figure 7 Gold alloy. Corrosion attacks in grain boundaries.

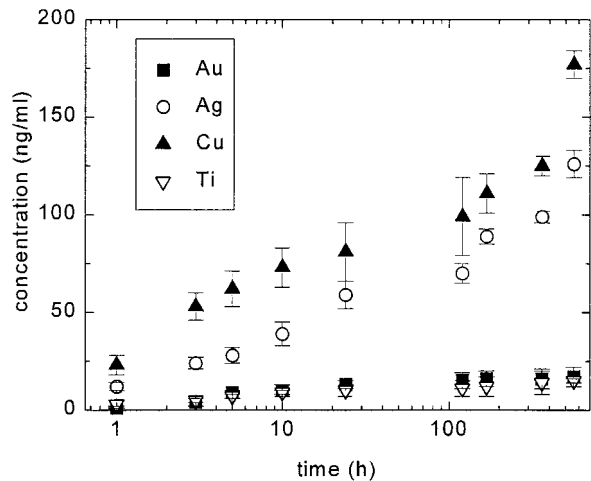

Figure 8 Ion release to the saliva from the gold alloy.



Figure 9 Microstructure of the palladium alloy.

mainly released is copper, but it does not exceed 175 ng/ml after 560 h.

Palladium alloy did not show pitting corrosion as can be observed in Fig. 9. However, selective dissolution of copper-rich phases was observed through energy dispersive X-ray analysis. This alloy had low critical current density, this fact may be due to the gallium in this composition. Because palladium is a gas-occluding metal when molten, it contributes to casting porosity. This requires the addition of some oxidizers, such as gallium.

Gallium prevents gas absorption and decreases pitting corrosion [16]. The palladium base alloy without or with low silver concentrations exhibited lower corrosion current densities and increased resistance to sulfide tarnish than the palladium-silver alloy. In this alloy selective dissolution of copper-rich phases was observed [18].

The Palladium alloy joined to the titanium oral implant reveals a very small palladium ion release, about 20 ng/ml after 560 h, but a significant release of other ions such as copper and gallium are detected, specially after 100 h. The results are shown in Fig. 10.

Base metal alloys

The higher costs of materials have encouraged the development of various base-alloy compositions. Major components of these alloys include either nickel, cobalt, copper, iron or titanium. In contrast, to the noble and semi-noble alloys, these metals are not as thermodynamically stable, and a major aspect of their corrosion resistance is related to the formation of a thin, protective oxide film (passive film) on the surface of the metal. If the oxide film is disrupted, then the metal or alloy must re-passivate in order for the material to be protected. This stability and the ability of the passive film to reform are important considerations when the overall corrosion properties of these alloys are being determined.

Commercially pure titanium are used for dental implants. Its use in suprastructure coupled to a titanium implant would produce an important decrease in the galvanic corrosion as has been showed in the results of this paper, as galvanic corrosion can occur when different alloys are placed in direct contact with the oral cavity or within tissues.

Titanium is one of the most corrosion-resistant materials used for biomedical applications. The oxide that forms on titanium provides the corrosion resistance under static conditions, and it has often been reported that titanium is not susceptible to pitting and/or crevice corrosion phenomena. However, it should be pointed out that the oxide film is not sufficiently stable to prevent galling and seizing under loading conditions [6]. This, under these conditions, the titanium oxide can be

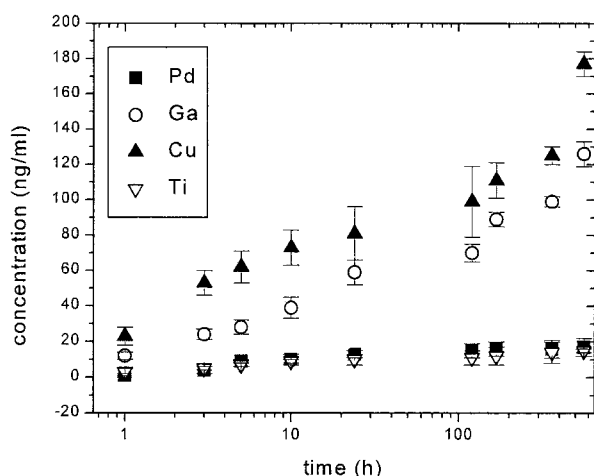

Figure 10 Ion release to the saliva from the palladium alloy.

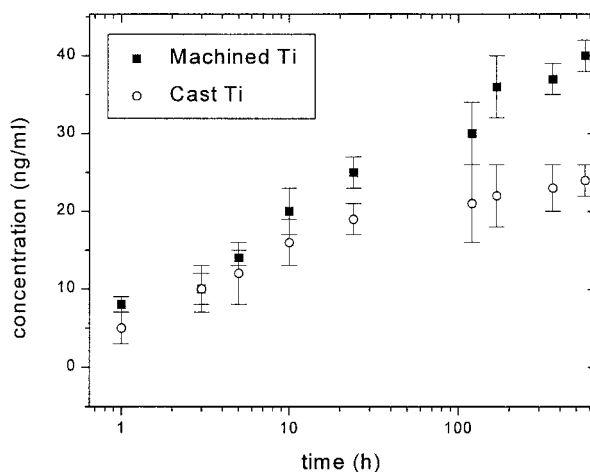

Figure 11 Ion release to the saliva from the cast and machined titanium.

removed, resulting in the release of metallic debris and ions. These properties could represent a limitations related to some dental applications.

Fig. 11 shows the cast and machined titanium ion release of 25 ng/ml and 40 ng/ml after 560 h, respectively, a larger amount than the oral implant when this was studied separately (15 ng/ml) with a similar surface in contact with the saliva. The difference between the values of the cast and machined titanium coupled oral implant is due to the corrosive process that takes place. Although both metals are titanium, and, generally, corrosion is not be expected in galvanic equals, it is in fact produced due to the fact that the two titanium pieces have different grades of purity, geometry, grain sizes, finished surface and internal stresses. However, the ion release observed is small enough, at least in the short term [2–3].

Chromium is added to the nickel-based alloys to improve the alloy ability to form a protective oxide film on the surface. It has been suggested that a chromium content from 16–27% will provide an optimum corrosion resistance for the nickel-based alloys, while the addition of molybdenum will also further enhances the corrosion resistance [22]. Alloys with lower chromium content may not be able to develop oxide films adequate for corrosion resistance.

The microstructure of the nickel-chromium alloy before corrosion test is shown in the Fig. 12. This reveals its dendritic structure and an eutectic phase, which is susceptible to preferential corrosion [23–25]. In Fig. 13 and 14 can be observed an etched surface showing the corrosion of preferential phase of the eutectic and thus a disruption of the oxide film. This alloy presents a localized corrosion phenomena. The phases formed by the minor alloying elements have been shown to have a significant effect on the corrosion properties of the nickel-based alloys [17].

The results of the ion release show that the chromium-nickel alloy liberates the largest amount of ions. The copper release is 200 ng/ml in the 10 first hours after the combination has been submerged in saliva and the ion release is also very important, 240 ng/ml after 560 h, as can be appreciated in Fig. 15. The high quantity of

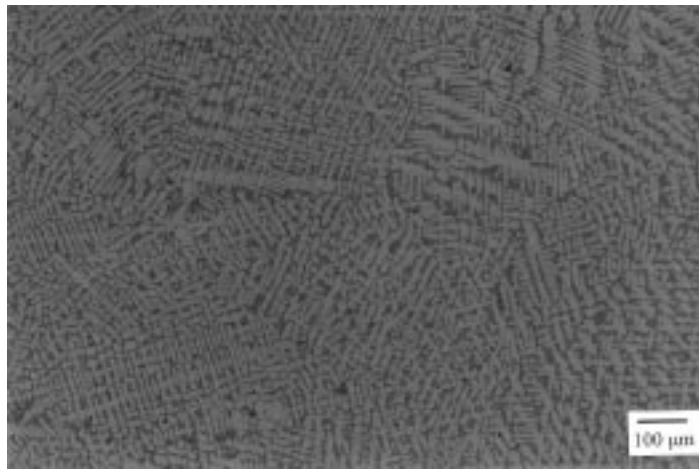

Figure 12 Microstructure of the nickel-chromium alloy.

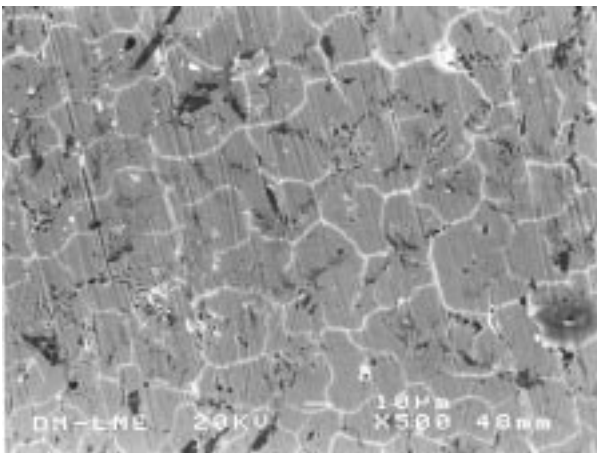

Figure 13 Corrosion of preferential phase on the nickel-chromium alloy.

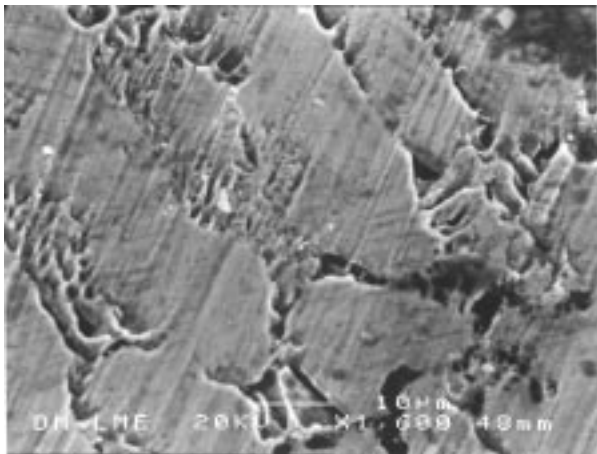

Figure 14 Corrosion of preferential phase on the nickel-chromium alloy.

copper released has been observed in the gold and palladium couples, this element is introduced in the dental alloys in order to improve the castability but it can produce toxicity. The same occurs with the nickel release in this alloy, as the organism may be injured (risk of sensitization) by the presence of this element. The chromium and molybdenum ions increase slowly and reach levels of 80 ng/ml in the solution at 560h. This greater ion release in the environment can be justified

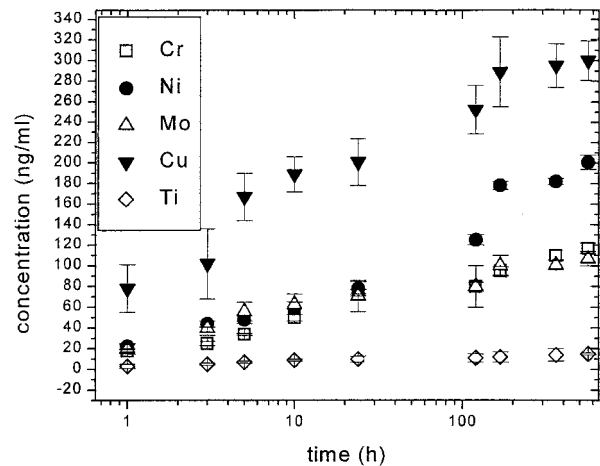

Figure 15 Ion release to the saliva from the nickel-chromium alloy.

because this alloy presents the lowest corrosion resistance and accordingly a larger amount of corrosion products are released to the environment.

Acknowledgments

The authors are grateful to Klockner and CICYT for the financial support of this study with reference MAT 98-0415.

References

1. J. GEIS-GERSTORFER, "In vitro corrosion measurements of dental alloys," *J. Dent.* **22** (1994) 247.
2. P. BRÅNEMARK, I. HANSSON, R. ADELL, U. LINDSTROM, J. HALLEN and O. OHMAN, "Osseointegrated implants in the treatment of the edentulous jaw. Experience from a 10-year period," *Scand. J. Plast. Reconstr. Surg.* **11** Suppl. 16 (1977).
3. R. ADELL, U. LEKHOLM, U. ROCKER and P. BRÅNEMARK, "A 15 year study of osseointegrated implants in the treatment of the edentulous jaw," *Int. J. Oral Surg.* **6** (1981) 387.
4. P. BRÅNEMARK, R. ADELL and T. ALBREKTSSON, "Osseointegrated titanium implants in the rehabilitation of the edentulous patient," *Adv. Biomaterials* **4** (1982) 133.
5. I. ERICSSON, U. LEKHOLM, P. BRÅNEMARK, J. LINDHE, P. O. GLANTZ and S. NYMAN, "A clinical evaluation of fixed bridge restorations supported by the combination of teeth and osseointegrated titanium implants," *J. Clin. Periodontol* **13** (1986) 307.

6. L. RECLARU and J. M. MEYER, "Study of corrosion between a titanium implant and dental alloys," *J. Dent.* **22** (1994) 159.
7. N. K. SAKAR, R. A. FUYS and J. W. STANFORD, "Applications of electrochemical techniques to characterize the corrosion of dental alloys" in B. C. Syrett, A. Acharya (eds.): *Corrosion and Degradation of Implant materials*. ASTM (1979) 277.
8. T. K. VAIDYANATHAN and A. PRASSAD, "In vitro corrosion and tarnish analysis of the Ag-Pd binary system," *J. Dent. Res.* **52** (1973) 828.
9. J. BRUGIRARD, R. BARGAIN and J. G. DEPUY, "Study of electrochemical behavior of gold dental alloys," *ibid.* **52** (1973) 828.
10. N. K. SAKAR, R. A. FUYS and J. W. STANFORD, "The chloride corrosion of low gold casting alloys," *ibid.* **58** (1979) 568.
11. *Idem.*, "The chloride corrosion of silver-base casting alloys," *ibid.* **58** (1979) 1572.
12. J. BRUGIRARD, "Étude du comportement électrochimique des métaux et alliages dentaires," Paris (1970) 62.
13. R. BABOIAN, "Electrochemical techniques for predicting galvanic corrosion". in R. Baboian, R. France, J. Roew, JF. Rynewicz eds. *Galvanic and Pitting corrosion-field and Laboratory studies*. Philadelphia, ASTM STP 576. (American Society for Testing and Materials 1976) 6.
14. F. MANSFELD and J. V. KENKEL, "Laboratory studies of galvanic corrosion of aluminium alloys" in *Galvanic and Pitting corrosion-field and Laboratory studies*, R. Baboian, R. France, J. Roew, JF. Rynewicz, edited by (ASTM STP 576. American Society for Testing and Materials, Philadelphia, 1976) 20.
15. F. MANSFELD, R. L. MEYERS and G. LAUER, "Instrumentation for corrosion studies" in *Low conductivity Media*, Technical Report Rockwell International (1973).
16. S. CANAY and M. ÖKTEMER, "in vitro corrosion behavior of 13 prosthodontic alloys," *Dental Res.* **23**(4) (1992) 279.
17. L. C. LUCAS and J. E. LEMONS, "Biodegradation of restorative metallic systems," *Adv. Dent. Res.* **6** (1992) 32.
18. T. K. VAIDYANATHAN and A. PRASAD, "In vitro corrosion and tarnish analysis of the Ag-Pd binary systems," *J. Dent. Res.* **60** (1981) 707.
19. M. MARECK, "Corrosion in a biological environment" in *Biocompatibility, toxicity and hypersensitivity to alloy systems used in dentistry*. (The University of Michigan School of Dentistry Ann. Arbor, MI). (1986) 103.
20. L. GETTLEMAN, F. H. COKS, L. A. DARMIENTO, P. A. LEVINE, S. WRIGHT and D. NATHANSON, "Measurements of in vivo corrosion rates in baboons and correlation with in vitro tests," *J. Dent. Res.* **59** (1980) 689.
21. L. W. LAUB and J. W. STANFORD, "Tarnish and corrosion behavior of dental gold alloys," *Gold Bull* **14** (1981) 13-18.
22. D. BRUNE, "Metal release from dental biomaterials," *Biomaterials* **7** (1996) 163.
23. J. LEE, L. LUCAS, J. O'NEAL, W. LACEFIELD and J. LEMANS, "In vitro corrosion analysis of nickel-based alloy," *J. Dent. Res.* **64** (1985) 317.
24. H. HERO, J. VALDERLANG and R. B. JOGENSEN, "Corrosion in vivo and in vitro of a commercial NiCrBe alloy," *Dent. Mater* **3** (1987) 324.
25. B. I. JOHANSSON, L. C. LUCAS and J. E. LEMONS, "Corrosion of dental copper, nickel and gold dental casting alloys: an in vitro and in vivo study," *J. Biomed. Mater. Res.* **23** (1989) 349.

*Received 13 November 1998
and accepted 21 June 1999*